



Dinamica generale s.r.l.
Weight systems and automation

Via Mondadori, 15 – CAP. 46025
 Poggio Rusco (Mantova) – Italy

TEL. ++39 (0) 386 – 52134
 FAX ++39 (0) 386 – 51523

E-mail info@dinamicagenerale.com
 Web www.dinamicagenerale.com



ISO 9001 : 2000



ISO 14001

AUTOLEVEL

**For levelling
 all your equipments**

Universal microprocessor device able to automatically level any platforms thanks to 2 double-acting hydraulic pistons.

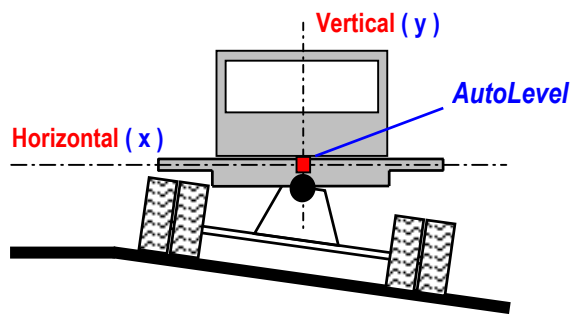
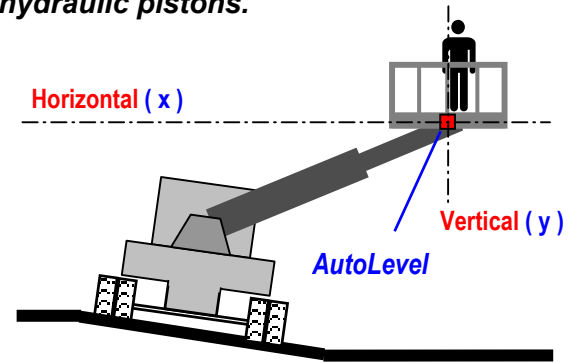

- Working temperature: - 20 / + 60 °C
- Case: in metal watertight IP 66 protection
- Dimensions: 120 x 122 x 80 mm
- Weight: < 1,2 kg
- Angle of intervention: adjustable da - 10° a + 10°, accuracy di ± 0,1° (factory set at ± 1°)
- Delay of intervention: regulatable da 0,5 a 4 seconds
- Positive power supply: 12V typical (10V min ÷ 24V max)
- Negative power supply: 0V

Positive logic output:

Reaching of the intervention angle	↔	OUT=1	↔	Output PIN = Power supply voltage (max current = 4 A)
Not reaching of the intervention angle	↔	OUT=0	↔	Output PIN = Open circuit

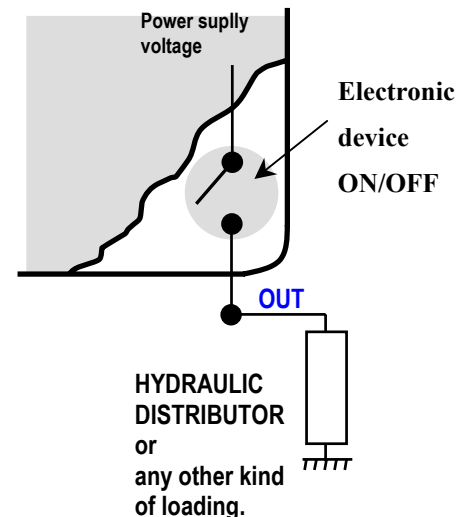

The output is caught from the emitter of a power transistor and it can directly drive the loading.

ORDER CODE :

Bi-Axis cod. 999-0014

Adjustment of the x,y axis

Mono-Axis

cod. 999-0013

Adjustment of the x axis